

# SPECIAL TOOLS

Customized Tool for  
Individual Requirements

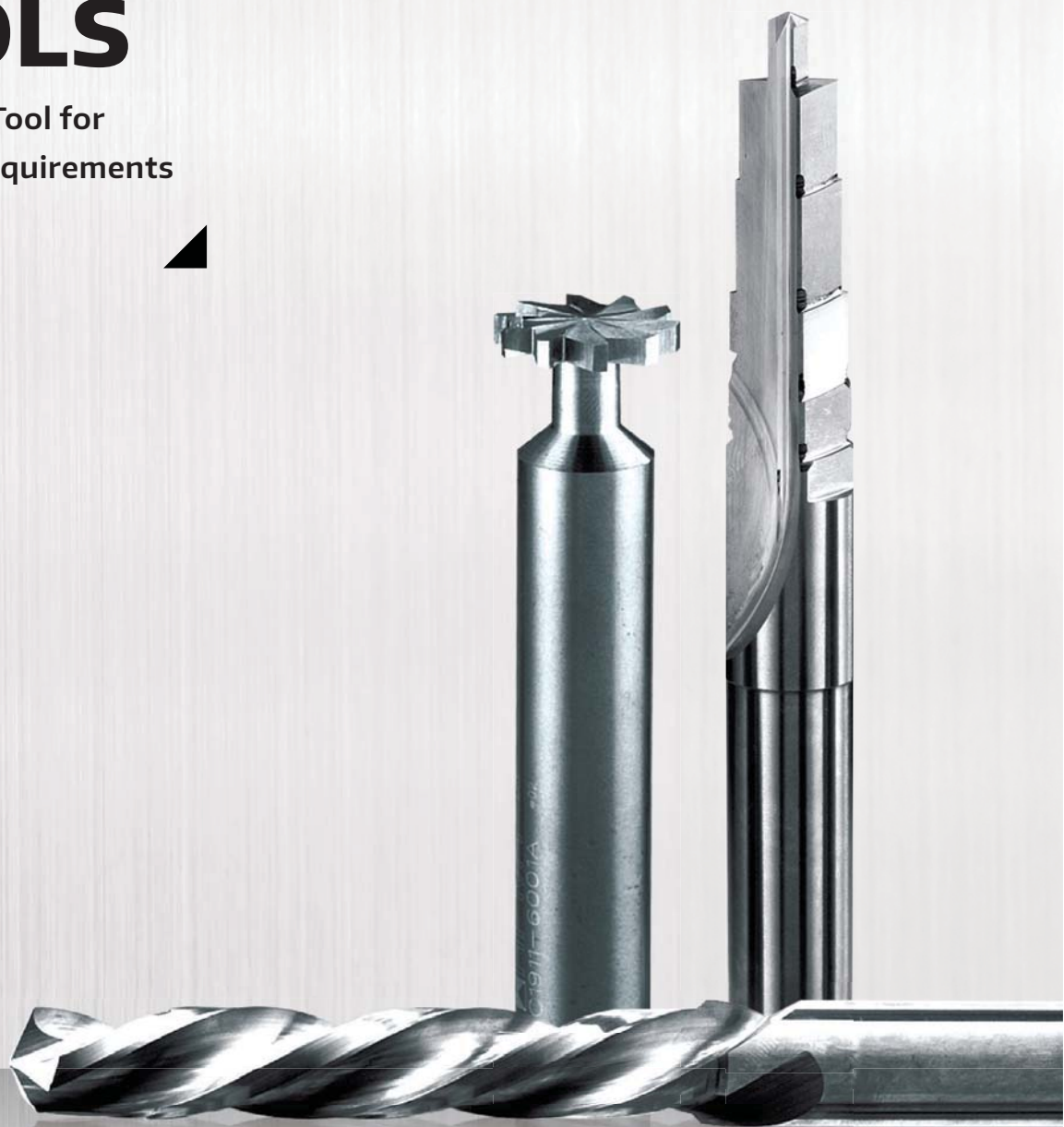

**ENDMILL**

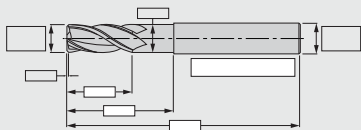

**ENDMILL WITH CORNER RADIUS**

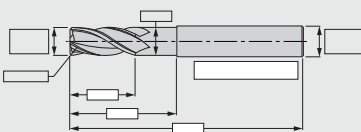

PAGE 552

**STEP ENDMILL**

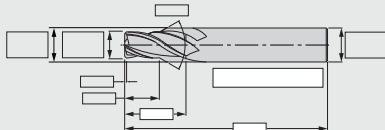

**CORNER RADIUS CUTTER**

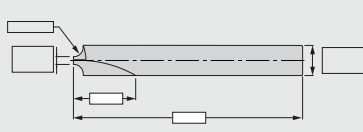

PAGE 552

**BALLNOSE**

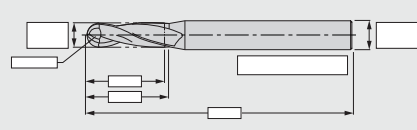

**TAPER BALLNOSE**

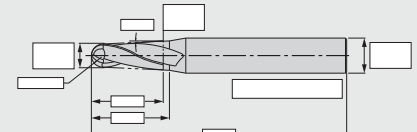

PAGE 552

**TAPER ENDMILL**

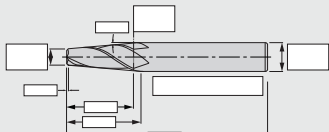

**TAPER ENDMILL WITH CORNER RADIUS**

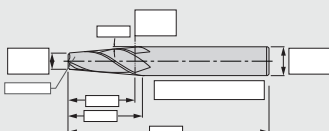

PAGE 552

**STEP REAMER**

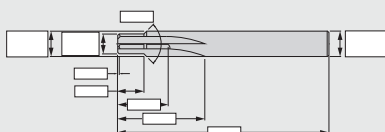

**T-SLOT ENDMILL**

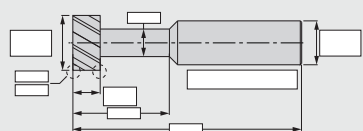

PAGE 552

**STRAIGHT FLUTE REAMER**

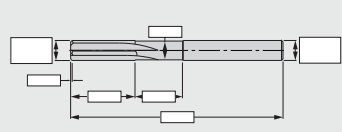

**SPIRAL REAMER**

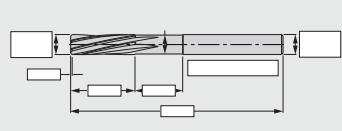

PAGE 552

**TWIST DRILL**

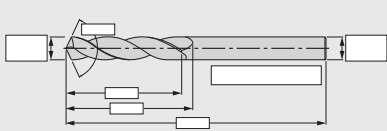

**STEP TWIST DRILL**

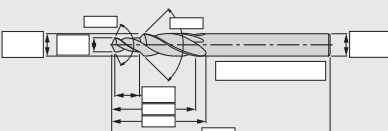

**BURNISHING DRILL**

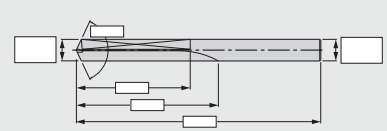

**NC SPOT DRILL**

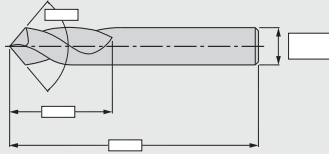

**CENTER DRILL**

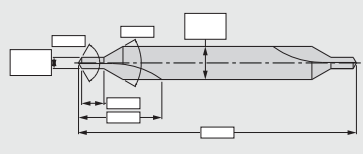

**STEP BURNISHING DRILL**

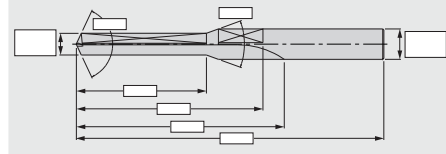

PAGE 552

PAGE 552

PAGE 552

# ENDMILLS

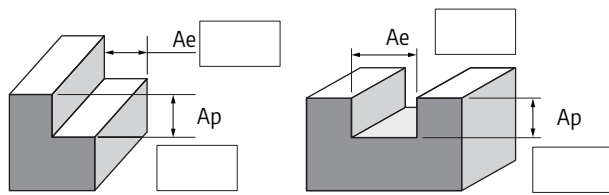

NUMBER OF FLUTE

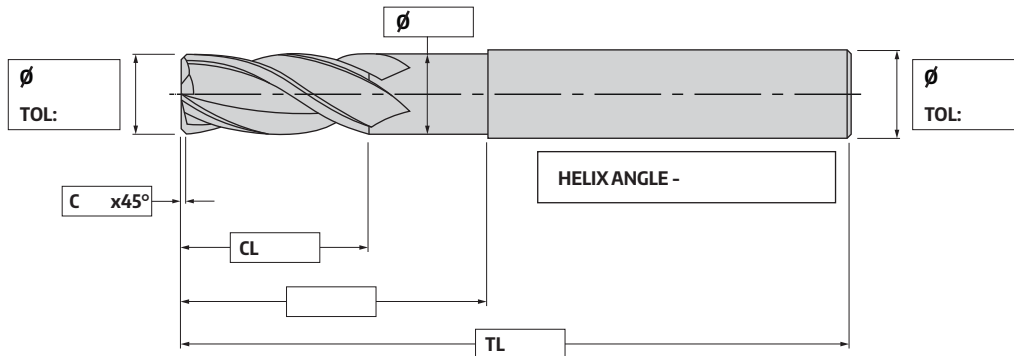
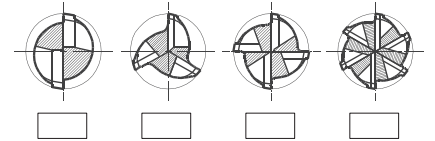

Customer's Name			Material	VHM	
Person (Mr/Ms)			Material to be Cut		
Enquiry Number			Coating		
Cutting Conditions	Vc:	Vf:	Coolant	Dry	Wet
Date:	Quantity:		Remark		

# ENDMILLS WITH CORNER RADIUS

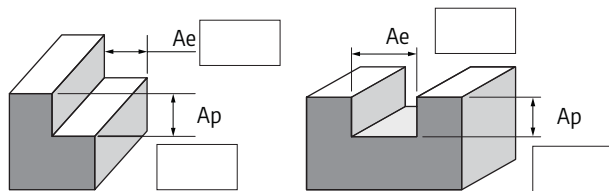

NUMBER OF FLUTE

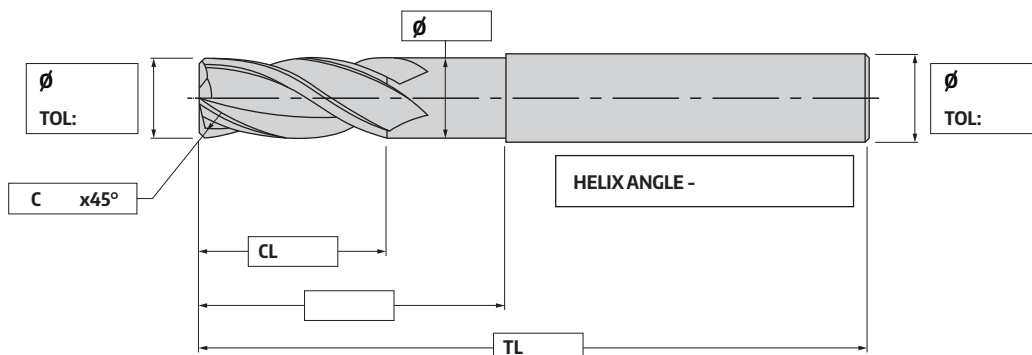
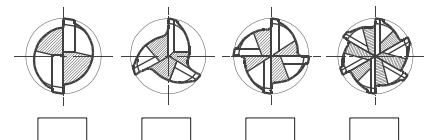

Customer's Name			Material	VHM	
Person (Mr/Ms)			Material to be Cut		
Enquiry Number			Coating		
Cutting Conditions	Vc:	Vf:	Coolant	Dry	Wet
Date:	Quantity:		Remark		

# STEP ENDMILL

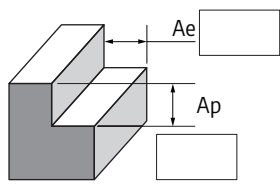

NUMBER OF FLUTE

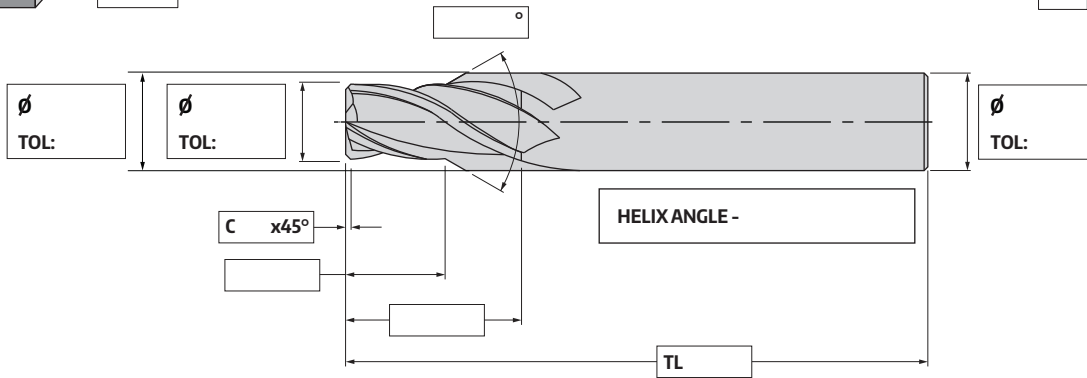
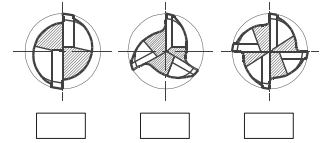

Customer's Name			Material	VHM	
Person (Mr/Ms)			Material to be Cut		
Enquiry Number			Coating		
Cutting Conditions	Vc:	Vf:	Coolant	Dry	Wet
Date:	Quantity:		Remark		

# CORNER RADIUS CUTTER



NUMBER OF FLUTE

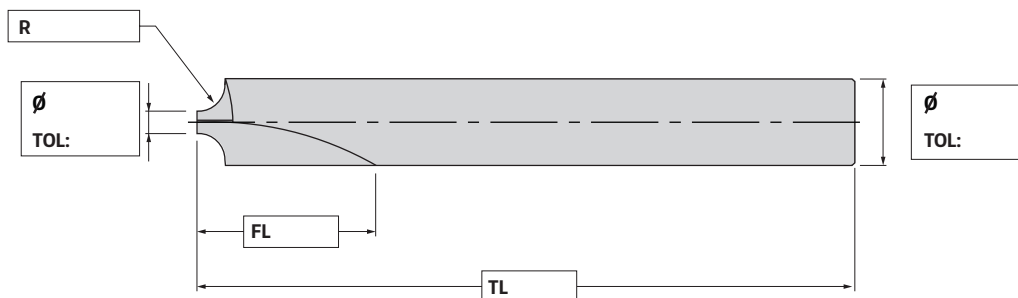
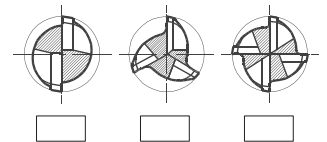

Customer's Name			Material	VHM	
Person (Mr/Ms)			Material to be Cut		
Enquiry Number			Coating		
Cutting Conditions	Vc:	Vf:	Coolant	Dry	Wet
Date:	Quantity:		Remark		

# BALLNOSE



NUMBER OF FLUTE

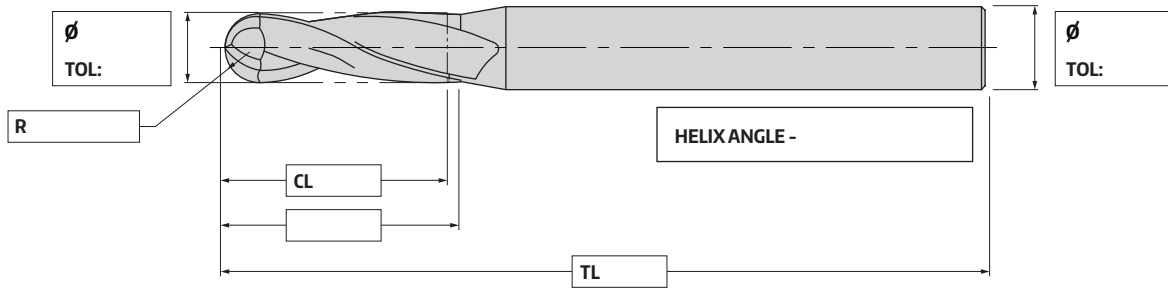
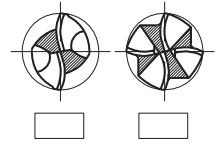

Customer's Name			Material	VHM	
Person (Mr/Ms)			Material to be Cut		
Enquiry Number			Coating		
Cutting Conditions	Vc:	Vf:	Coolant	Dry	Wet
Date:	Quantity:		Remark		

# TAPER BALLNOSE



NUMBER OF FLUTE

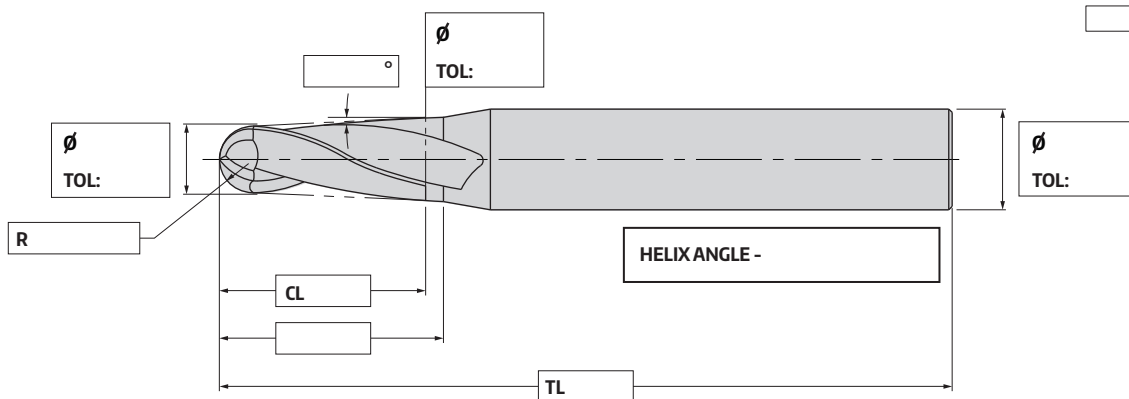
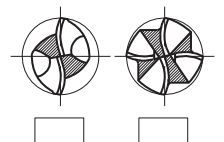

Customer's Name			Material	VHM	
Person (Mr/Ms)			Material to be Cut		
Enquiry Number			Coating		
Cutting Conditions	Vc:	Vf:	Coolant	Dry	Wet
Date:	Quantity:		Remark		

# TAPER ENDMILL



NUMBER OF FLUTE

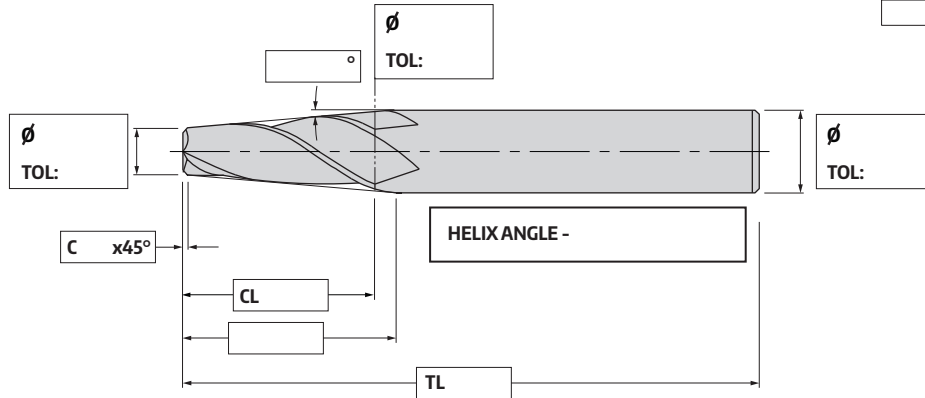
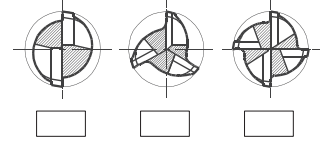

Customer's Name		Material	VHM	
Person (Mr/Ms)		Material to be Cut		
Enquiry Number		Coating		
Cutting Conditions	Vc:	Vf:	Coolant	Dry Wet
Date:	Quantity:	Remark		

# TAPER ENDMILL WITH CORNER RADIUS



NUMBER OF FLUTE

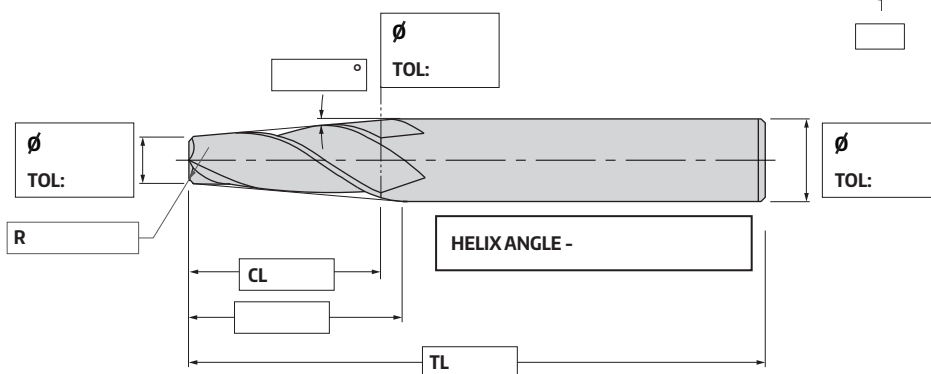
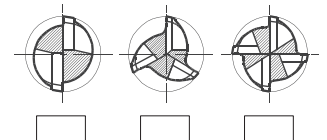

Customer's Name		Material	VHM	
Person (Mr/Ms)		Material to be Cut		
Enquiry Number		Coating		
Cutting Conditions	Vc:	Vf:	Coolant	Dry Wet
Date:	Quantity:	Remark		

# STEP REAMER



## TYPE OF FLUTE

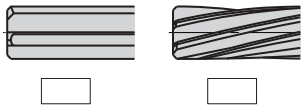

HELIX ANGLE -

## NUMBER OF FLUTE

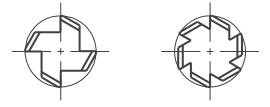

LEFT HAND SPIRAL     LEFT HAND CUTTING  
 RIGHT HAND SPIRAL     RIGHT HAND CUTTING

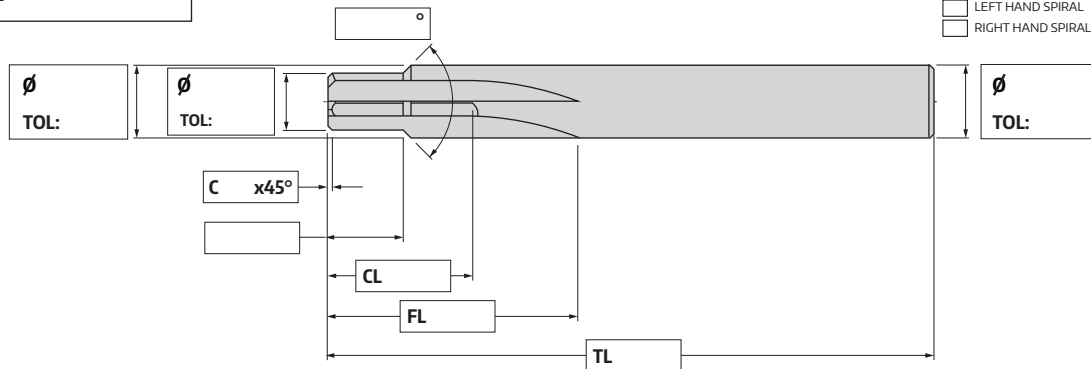

Customer's Name			Material	VHM	
Person (Mr/Ms)			Material to be Cut		
Enquiry Number			Coating		
Cutting Conditions	Vc:	Vf:	Coolant	Dry	Wet
Date:	Quantity:		Remark		

# T-SLOT CUTTER



## NUMBER OF FLUTE

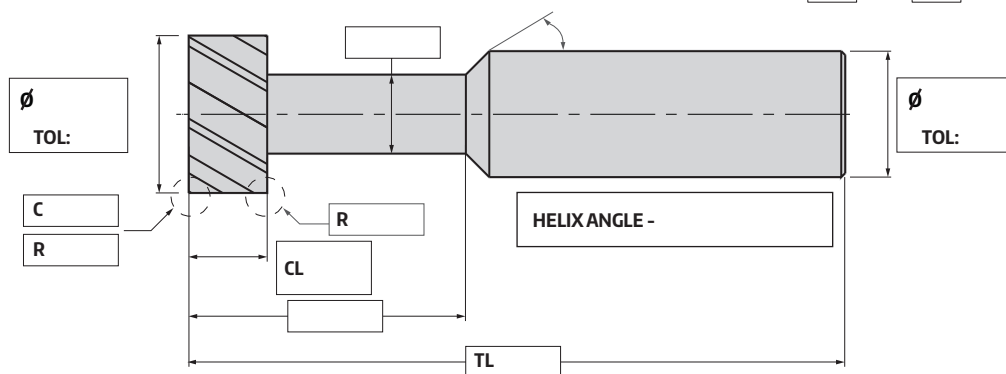
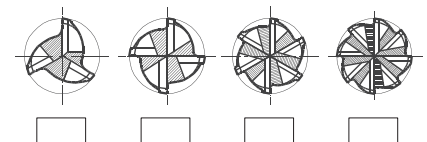

Customer's Name			Material	VHM	
Person (Mr/Ms)			Material to be Cut		
Enquiry Number			Coating		
Cutting Conditions	Vc:	Vf:	Coolant	Dry	Wet
Date:	Quantity:		Remark		

# STRAIGHT FLUTE REAMER



NUMBER OF FLUTE

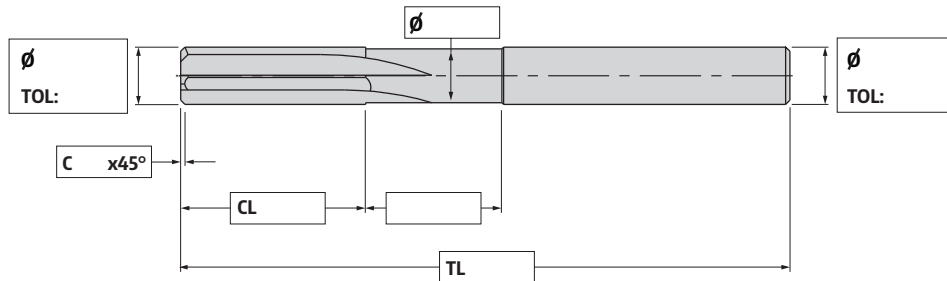
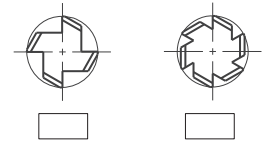

Customer's Name			Material	VHM	
Person (Mr/Ms)			Material to be Cut		
Enquiry Number			Coating		
Cutting Conditions	Vc:	Vf:	Coolant	Dry	Wet
Date:	Quantity:		Remark		

# SPIRAL REAMER



HIGH SPIRAL

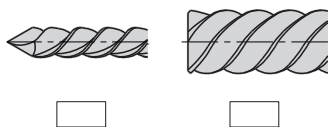

NUMBER OF FLUTE

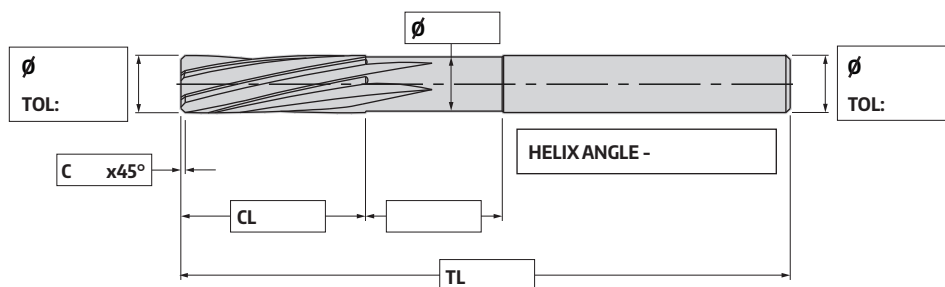
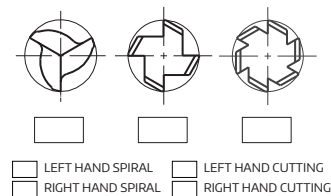

Customer's Name			Material	VHM	
Person (Mr/Ms)			Material to be Cut		
Enquiry Number			Coating		
Cutting Conditions	Vc:	Vf:	Coolant	Dry	Wet
Date:	Quantity:		Remark		



# TWIST DRILL



## NUMBER OF FLUTE

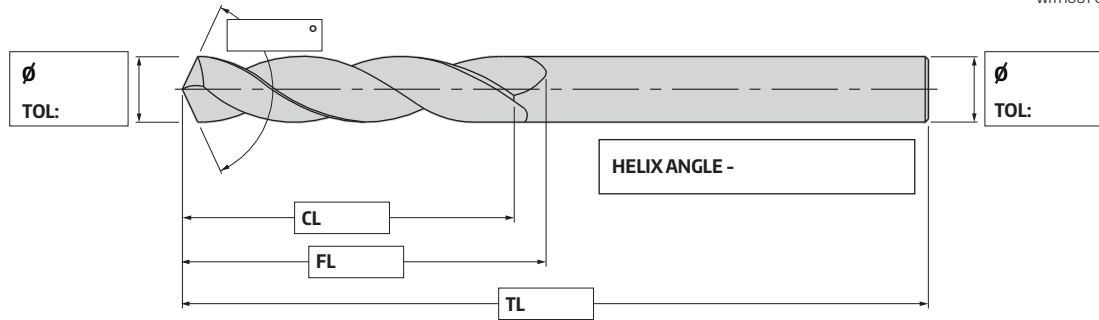
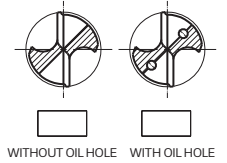

Customer's Name			Material	VHM	
Person (Mr/Ms)			Material to be Cut		
Enquiry Number			Coating		
Cutting Conditions	Vc:	Vf:	Coolant	Dry	Wet
Date:	Quantity:		Remark		

# NC SPOT DRILL

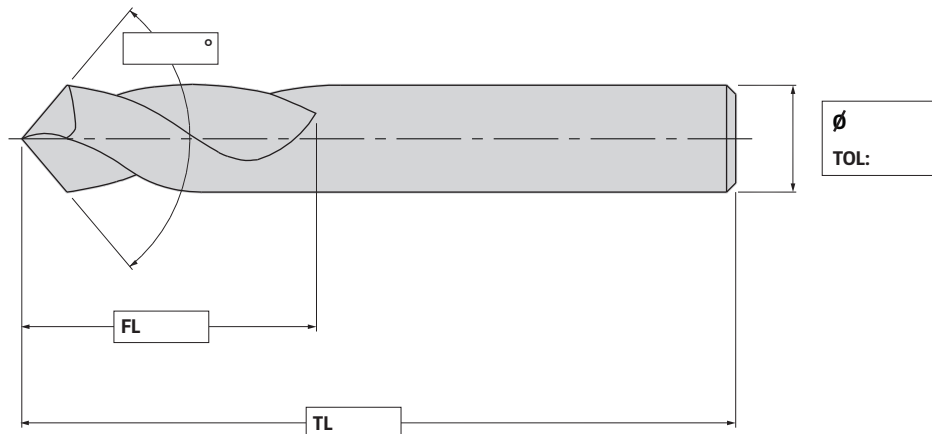

Customer's Name			Material	VHM	
Person (Mr/Ms)			Material to be Cut		
Enquiry Number			Coating		
Cutting Conditions	Vc:	Vf:	Coolant	Dry	Wet
Date:	Quantity:		Remark		

# STEP TWIST DRILL

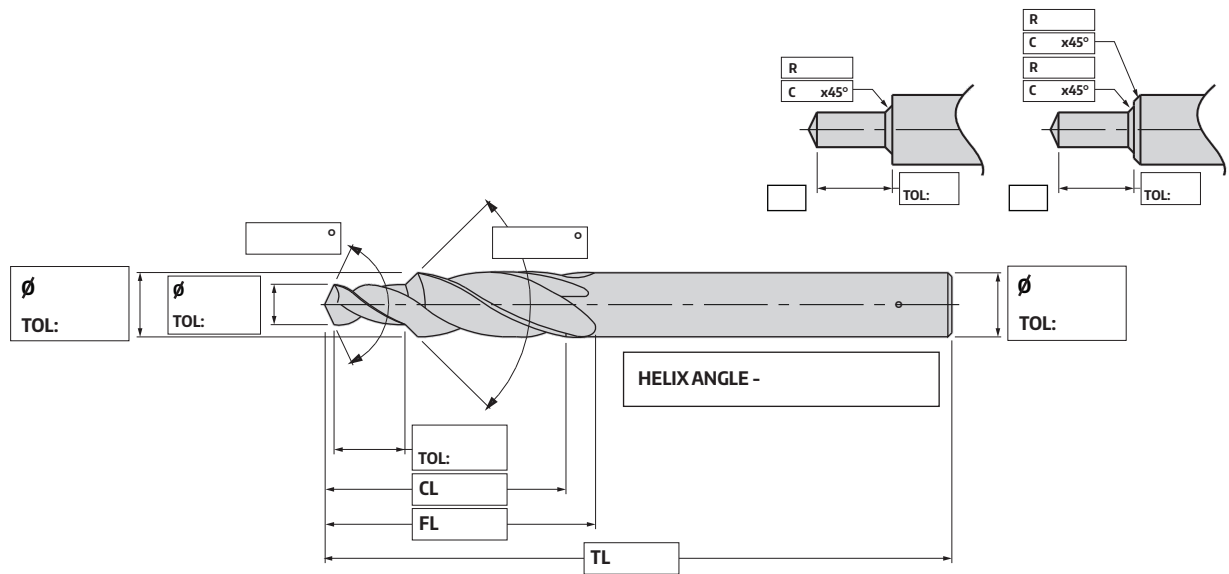

Customer's Name		Material	VHM	
Person (Mr/Ms)		Material to be Cut		
Enquiry Number		Coating		
Cutting Conditions	Vc:	Vf:	Coolant	Dry Wet
Date:	Quantity:	Remark		

# CENTER DRILL

## TYPE OF FLUTE

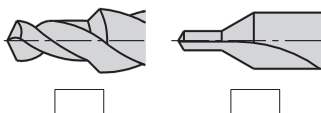

HELIX ANGLE -

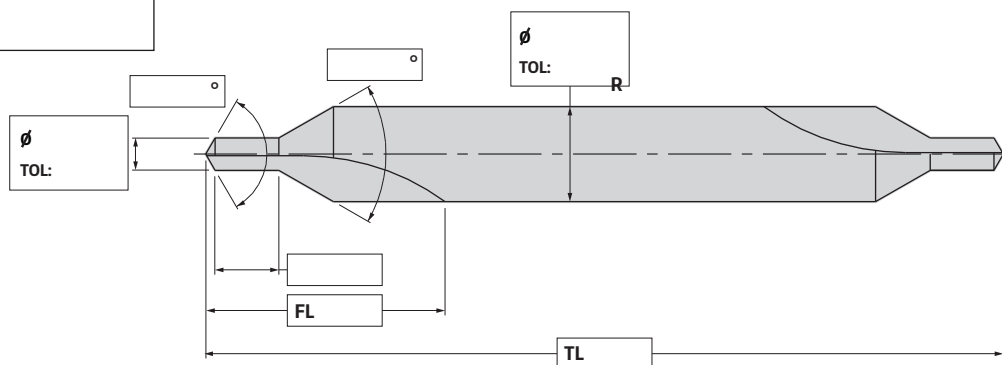

Customer's Name		Material	VHM	
Person (Mr/Ms)		Material to be Cut		
Enquiry Number		Coating		
Cutting Conditions	Vc:	Vf:	Coolant	Dry Wet
Date:	Quantity:	Remark		

# BURNISHING DRILL

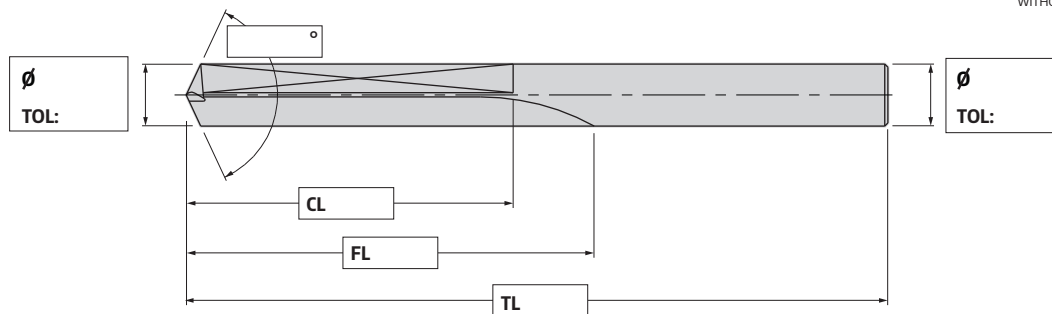
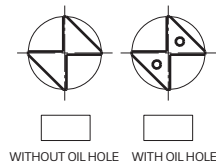

Customer's Name			Material	VHM	
Person (Mr/Ms)			Material to be Cut		
Enquiry Number			Coating		
Cutting Conditions	Vc:	Vf:	Coolant	Dry	Wet
Date:	Quantity:		Remark		

# STEP BURNISHING DRILL

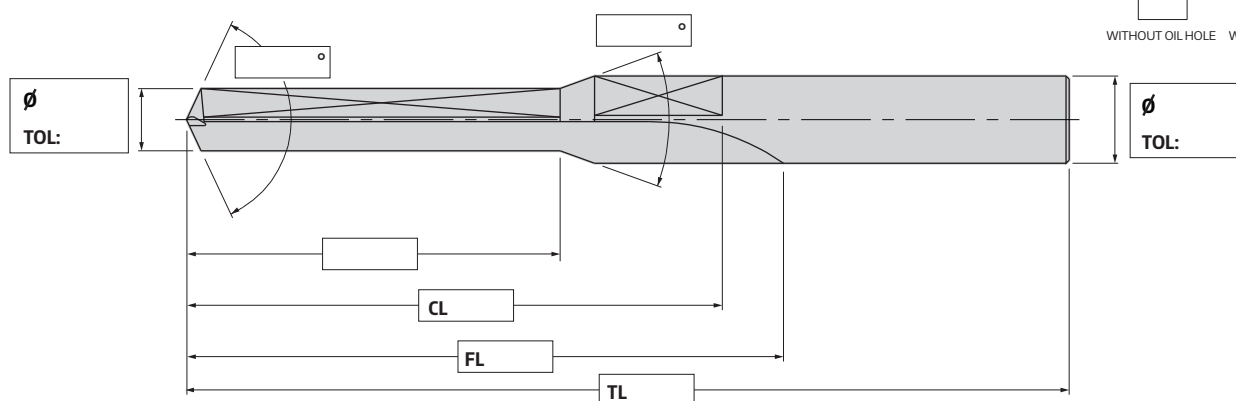
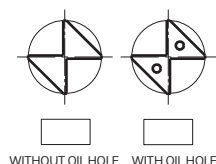

Customer's Name			Material	VHM	
Person (Mr/Ms)			Material to be Cut		
Enquiry Number			Coating		
Cutting Conditions	Vc:	Vf:	Coolant	Dry	Wet
Date:	Quantity:		Remark		